

MADE IN THE USA,
PLAYED ON
WORLDWIDE™



“ As a big guy and former athlete, I needed an athletic surface that would be forgiving on these old knees. Their revolutionary SnapSports ShockTower athletic surface has built in shock absorbcency and it was a no-brainer for me. ”

~ Shaquille O'Neal – 4x NBA Champion

“ ”



INDOORS OR OUT, SNAPSPORTS® IS THE ATHLETIC SURFACE FOR YOUR FACILITY

Three generations of continuous innovation, design, and product development have made SnapSports Athletic Surfaces the clear industry leader. With patented performance, a **16-year warranty**, and safe play technologies such as ShockTower®, TuffShield®, ShockLock®, and more, there's no other modular sports flooring system that delivers this level of quality, durability, safety, and performance. SnapSports Athletic Surfaces are tested in the lab and proven at the highest levels of athletic competition. Whether for a weekend tournament or decades of competitive play, SnapSports delivers.

SnapSports Athletic Surfaces are a great choice for the following facilities:

- Schools
- Family Life Centers
- Multi-Activity Centers
- Rehab Clinics and Hospitals
- Sports Training Facilities
- Arenas
- Parks
- Churches
- Recreation Centers
- Sports Camps
- Military
- Private Athletic Clubs
- Exposition Centers
- Gyms



Basketball Courts

Player performance, ball response, and safety are all incorporated into the design of our basketball surfacing. Professionals and amateurs alike know that when the game is on, they can expect performance from SnapSports.





Volleyball Courts

Our volleyball courts have proven themselves time and again as safe, high-performance surfaces. The official flooring of the **Big South National Qualifier**.



Futsal Pitches

SnapSports surfaces are **United States Futsal Federation** approved and have appeared in many national and international tournaments.



Multi-Courts

If you're hosting a basketball game one day and a Pickleball tournament the next, SnapSports Multi-Sport surfaces are up to the challenge.



Pickleball Courts

Maximize court usage by offering a variety of racquet sports—SnapSports surfaces are great for paddle tennis, pickleball and more!



Inline Hockey Rinks

Our amazingly fast surfaces provide plenty of action and are a popular choice for recreation centers that require a long lasting floor for roller sport activities.



Tennis Courts

Our **ITF certified fast** tennis courts provide paramount ball performance, never crack, and are virtually maintenance free.



Revolution with light maple TuffShield® in a basketball and futsal facility

Key Benefits

- Top rated high-performance athletic surface
- Patented **ShockLock**® system absorbs lateral impact
- Moisture, humidity, and temperature-resistant
- Suitable for multiple sports and activities
- Create a new floor or retrofit most gyms in 24 – 48 hours
- Low annual maintenance
- **Vertical and lateral shock absorption** for player safety
- Free-floating surface is portable or permanent, no adhesives or anchoring required
- 20 Colors available

Options

- **ShockTower**® high-performance suspension
- Light maple, dark maple, or transparent TuffShield finish
- Parquet pattern
- Custom logos and graphics
- CourtKeeper™ cushion/acoustic mat

Specs

Dimensions: 12" x 12" x 5/8" (305 mm x 305 mm x 16 mm)

Weight: 15 – 25 oz. (425 – 709 g)

Material: High impact copolymer

Friction: 0.77 Dry (ASTM C 1028)

Ball Rebound: 98% (DIN 18032-02)

Force Reduction: Class 1/ Class 2 (ASTM F2772)

For Architectural Specifications, Please Visit Our Website:

www.snapsports.com/architect-toolbox/

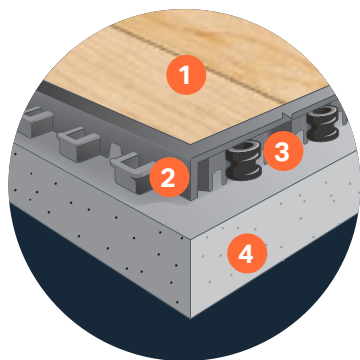

Full System Layers

1. TuffShield protective coating (optional)
2. Suspended sports surface
3. ShockTower (optional)
4. Concrete/subsurface



Revolution with Light Maple TuffShield at the NBA All-Star Event

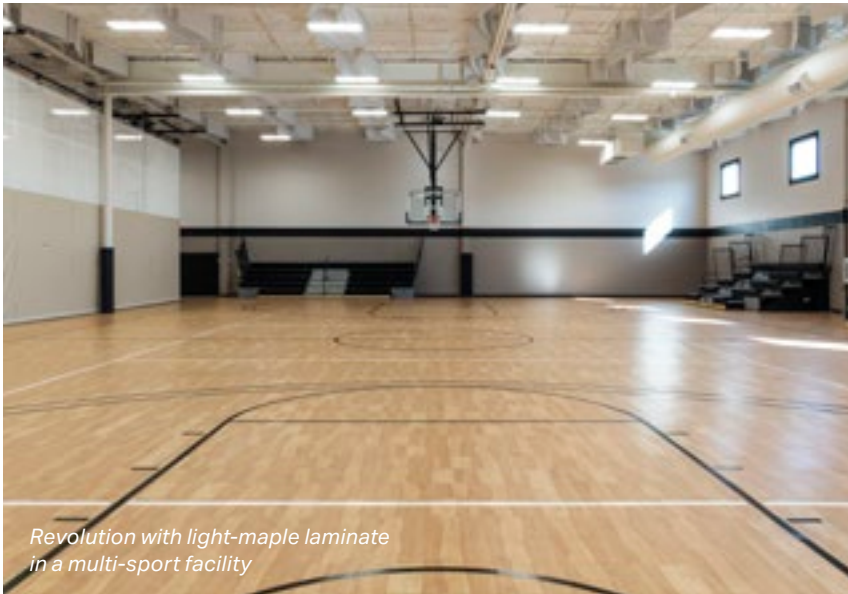

Revolution with light-maple laminate in a multi-sport facility

Maple Laminate

Traditional hardwood is expensive and maintenance intensive; forget all that with the durable, proprietary pressure-bonded finish.



Light Maple

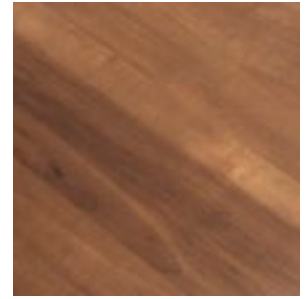

Dark Maple

TuffShield

Molded into the surface, patented TuffShield provides a durable and easy to clean surface that does not require costly humidity controls.



Light Maple

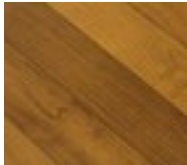

Dark Maple



Gray Maple

Also Available as a Transparent High-Gloss Finish Over Standard Colors

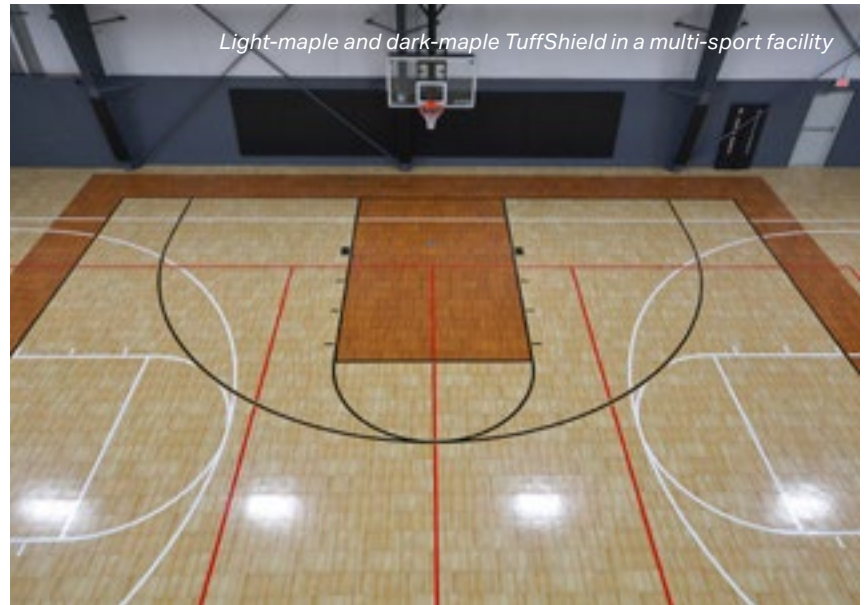

Light-maple and dark-maple TuffShield in a multi-sport facility



Standard Revolution multi-sport surface

Standard

With 20 standard colors to choose from, you're sure to find the color that suits your needs.

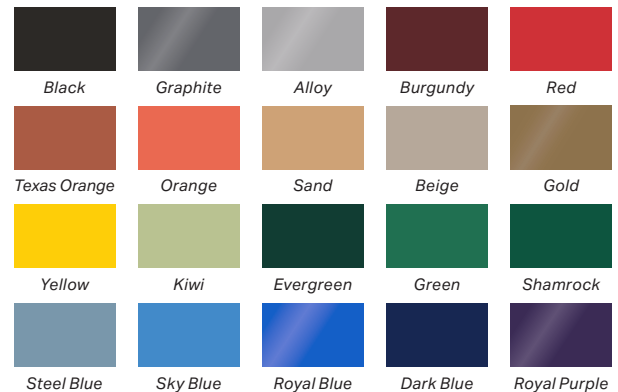

Due to printing limitations and different lighting situations, colors seen may not be accurate. Color chips are available upon request.



Pro36 at the NBA Centre Court

Key Benefits

- Industry's largest modular sports surface (9 sq. ft.)
- Designed for outstanding basketball performance
- Classic wood look
- Moisture, humidity, and temperature-resistant
- Versatile for multiple sports and activities
- Create a new floor or retrofit most gyms in 24 – 48 hours
- Low annual maintenance
- **Vertical and lateral shock absorption** for player safety
- Free-floating surface is portable or permanent, no adhesives or anchoring required

Options

- **ShockTower®** high-performance suspension
- Custom logos and graphics
- CourtKeeper™ cushion/acoustic mat

Specs

Dimensions: 36" x 36" x 11/16" (914.4 mm x 914.4 mm x 17.4 mm)

Weight: 208 oz. (5896.7 g)

Material: High impact copolymer with commercial laminate

Suspension: full-suspension support legs

Friction: 0.77 Dry (ASTM C 1028)

Ball Rebound: 98% (DIN 18032-02)

Force Reduction: Class 1/ Class 2 (ASTM F2772)

For Architectural Specifications Please Visit Our Website:

www.snapsports.com/architect-toolbox/

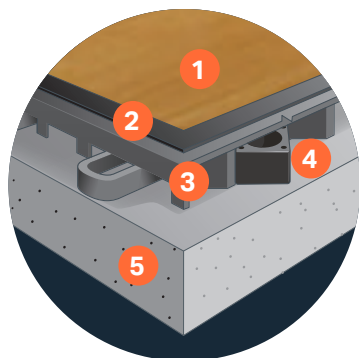

Full System Layers

1. Maple layer
2. Shock response layer
3. Suspended sports surface
4. ShockTower (optional)
5. Concrete/subsurface



School gym with Pro36

CLASSIC XL

Classic XL with maple in a church gym

Key Benefits

- Minimal initial investment vs hardwood
- **Low maintenance** costs
- Moisture, humidity, and temperature-resistant
- Create a new floor or retrofit most gyms in 24 – 48 hours
- Versatile for multiple sports and activities
- Competitively priced and **built to last**
- Free-floating surface is portable or permanent, no adhesives or anchoring required
- 20 Colors available

Options

- **ShockTower**® high-performance suspension
- Laminate surface for authentic maple look
- Parquet pattern
- Custom logos and graphics
- CourtKeeper™ cushion/acoustic mat

Specs

Dimensions: 18" x 18" x 1/2" (457 mm x 457 mm x 13 mm)

Weight: 40 – 62 oz. (1134 – 1758 g)

Material: High impact copolymer

Friction: 0.77 Dry (ASTM C 1028)

Ball Rebound: 98% (DIN 18032-02)

Force Reduction: Class 1/ Class 2 (ASTM F2772)

For Architectural Specifications Please Visit Our Website:

www.snapsports.com/architect-toolbox/

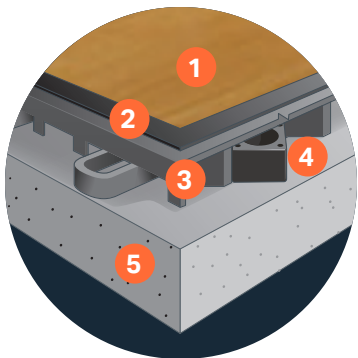

Full System Layers

1. Maple layer (optional)
2. Shock response layer (included with maple option)
3. Suspended sports surface
4. ShockTower (optional)
5. Concrete/subsurface



Inline hockey rink in Classic XL



Volleyball facility using 50-50 with ShockTower

Key Benefits

- Ideal for volleyball and futsal clubs and tournaments
- Conforms to international play standards
- **70% Fewer seams** for superior ball play and safety
- **25% Force reduction**
- 144 Impact zones for consistent and safe play
- Patented **ShockLock®** – absorbs lateral impact
- Unaffected by moisture, humidity, or temperature
- Fastest deployment of any modular sport surface
- Low annual maintenance
- Free-floating surface is portable or permanent, no adhesives or anchoring required
- 20 Colors available

Options

- **ShockTower®** high-performance suspension
- Custom logos and graphics
- CourtKeeper™ cushion/acoustic mat

Specs

Dimensions: 50 cm x 50 cm x 1.6 cm (19.685" x 19.685" x 5/8")

Weight: 42oz. (1197.46 g)

Material: High impact copolymer

Friction: 0.77 Dry (ASTM C 1028)

Ball Rebound: 98% (DIN 18032-02)

Force Reduction: Class 1/ Class 2 (ASTM F2772)

For Architectural Specifications Please Visit Our Website:

www.snapsports.com/architect-toolbox/

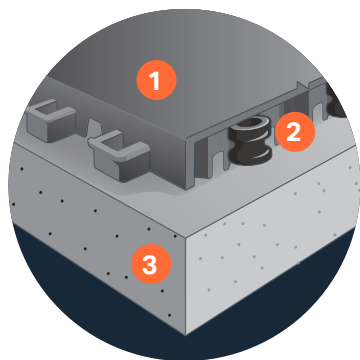

Full System Layers

1. Suspended sports surface
2. ShockTower (optional)
3. Concrete/subsurface

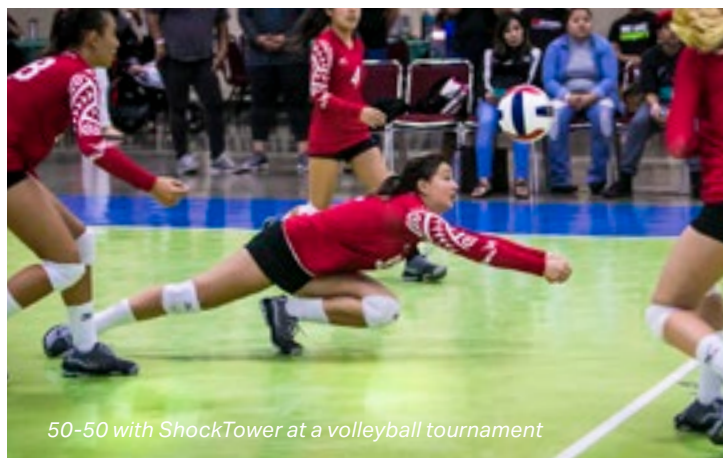

50-50 with ShockTower at a volleyball tournament



“ 41 full court basketball games going on at one time. In the Guinness book of world records, most gyms under one roof. 520 teams, 1100 coaches, 180 officials, 13,000 spectators, over 5,000 Athletes. We’re using SnapSports Flooring. ”

~ Matt Williams – Governor, AAU Pacific District



“SnapSports’ new Revolution Pickleball tile is a game changer. This is the only modular surface with true, consistent ball bounce. This will be great for anyone looking to play Pickleball recreationally.”

~ Tyler Loong – Pickleball Professional



PICKLEGRIP™

Outdoor Revolution on a community basketball court

Key Benefits

- Patented **ShockLock®** system absorbs lateral impacts
- Fast, true pickleball bounce
- Only modular sports surface engineered for Pickleball with patented PickleGrip technology
- Excellent **all-weather traction**
- Competitively priced high-performance athletic surface
- Open top design allows for immediate drainage
- Covers cracks, stains, and puddles
- Low annual maintenance
- **Vertical and lateral shock absorption** for player safety
- Free-floating surface is portable or permanent
- **UV stable**
- **ShockLock®** system keeps adjoining tiles the same height for consistent bounce—even on gravity drop shots
- 19 Colors available

Options

- Custom logos and graphics

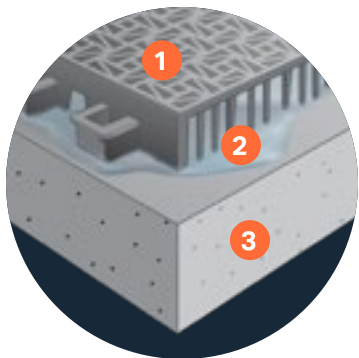

Full System Layers

1. Suspended sports surface
2. Self draining design
3. Concrete/subsurface

Specs

Dimensions: 12" x 12" x 5/8" (305 mm x 305 mm x 16mm)

Weight: 13 oz. (370.59 g)

Material: High impact copolymer

Friction: 0.65 Dry (ASTM C 1028)

Ball Rebound: 98% (DIN 18032-02)

Force Reduction: Class 1 (ASTM F2772)

For Architectural Specifications Please Visit Our Website:

www.snapsports.com/architect-toolbox/



Play multiple sports in addition to pickleball

OUTDOOR REVOLUTION®

Outdoor Revolution on a community basketball court

Key Benefits

- Patented **ShockLock®** system absorbs lateral impacts
- Excellent **all-weather traction**
- Competitively priced high-performance athletic surface
- Open top design allows for immediate drainage
- Covers cracks, stains, and puddles
- Low annual maintenance
- **Vertical and lateral shock absorption** for player safety
- Free-floating surface is portable or permanent, no adhesives or anchoring required
- **UV stable**
- 19 Colors available

Options

- **ShockTower®** high-performance suspension
- Optional high-traction polymer for wet environments
- Custom logos and graphics

Specs

Dimensions: 12" x 12" x 5/8" (305 mm x 305 mm x 16mm)

Weight: 13 oz. (370.59 g)

Material: High impact copolymer

Friction: 0.65 Dry (ASTM C 1028)

Ball Rebound: 98% (DIN 18032-02)

Force Reduction: Class 1 (ASTM F2772)

For Architectural Specifications Please Visit Our Website:

www.snapsports.com/architect-toolbox/

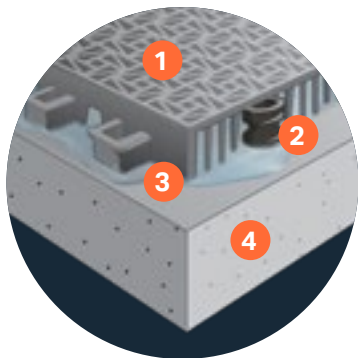

Full System Layers

1. Suspended sports surface
2. ShockTower (optional)
3. Self draining design
4. Concrete/subsurface



Outdoor Revolution at a Red Bull 3X event



DuraCourt on a multi-use court

Key Benefits

- Designed for an elegant, seamless finish
- Excellent **all-weather traction**
- Competitively priced high-performance athletic surface
- Open top design allows for immediate drainage
- Covers cracks, stains, and puddles
- Low annual maintenance
- Vertical and lateral shock absorption for player safety
- Free-floating surface is portable or permanent, no adhesives or anchoring required
- **UV stable**
- 19 Standard colors available

Options

- Custom logos and graphics

Specs

Dimensions: 12" x 12" x 5/8" (305 mm x 305 mm x 16mm)

Weight: 13 oz. (370.59 g)

Material: High impact copolymer

Friction: 0.65 Dry (ASTM C 1028)

Ball Rebound: 98% (DIN 18032-02)

Force Reduction: Class 1 (ASTM F2772)

For Architectural Specifications Please Visit Our Website:

www.snapsports.com/architect-toolbox/

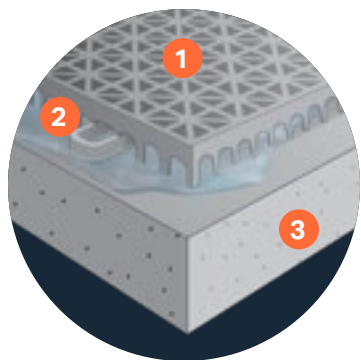

Full System Layers

1. Suspended sports surface
2. Self draining design
3. Concrete/subsurface



DuraCourt at an NBA event



LOGOS & GRAPHICS

YOU BRAND IT, WE BUILD IT

You're making a big investment in your court, why not make an even bigger statement with a custom logo? Our in-house design and production teams can create and apply nearly any logo or image to your court. Check out our socials for some of the thousands of custom logos we've installed worldwide.





SnapSports Retrofit Key Benefits

- Industry leading expertise in court repair and refurbishment
- Create a new floor or retrofit most gyms in **24 – 48 hours**
- High level sports performance (*tennis, basketball, futsal, pickleball, hockey, volleyball and more*)
- Four indoor and three outdoor surface families available
- Excellent coefficient of friction for athletic movement
- **All-weather courts** for year round use
- Low initial investment and annual upkeep costs
- Covers unsightly cracks, stains, wear, and puddles
- Free-floating, no anchors or adhesives required
- Multiple color and design options
- Custom logos, graphics and line designs available
- 16-Year warranty
- Recyclable

“ SnapSports helped us put together a first-class sport facility at the University of Wisconsin-Richland. Their service and commitment to the project were second to no contractor that I have dealt with in my tenure as Athletics Director at UW-R. (SnapSports) dedication to producing an end product that performed well and made us happy shows the company’s character. ”

~ Gail Hoffman – Athletics Director at UW-Richland

“ I left school on Friday night after the game and when I returned Monday morning we had a new beautiful gym floor. I could not believe the transformation over the weekend. The best thing about it was we didn’t have to cancel P.E. classes or the JV game on Monday. ”

~ Mike Smith – Head Basketball Coach at Summit High School



SHOCKTOWER®

The Only Modular Sports Flooring With Independent Shock Absorbers

Patented SnapSports technology gives an added level of "cush" to reduce impact on joints and limbs, letting you play longer today and for years to come.

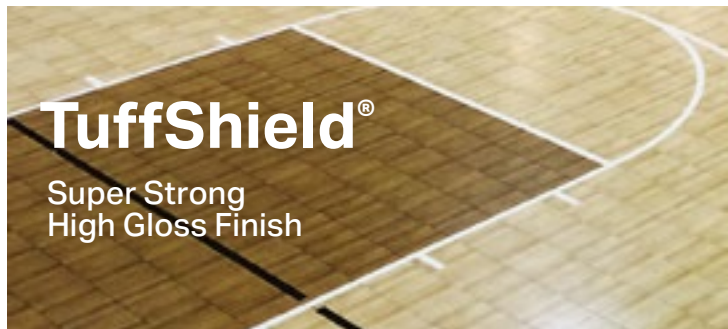
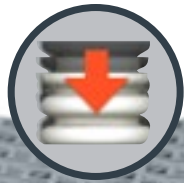

TuffShield®

Super Strong
High Gloss Finish

Provides polished and professional look without paint or decals. An easy to clean surface, resistant to petroleum products and most chemicals. Available in transparent; light, dark, and gray maple; and halo colors.



ShockLock®

"Give" built-in

The ShockLock system lets individual modules slide, but keeps the entire sport surface fully interlocked. This built-in "give" eases player joint impact and creates a safer athletic surface.



PickleGrip™

Our exclusive technology gives you the performance you'll need at a cost you'll love. Get superior ball bounce and grip with PickleGrip copolymer material, only from SnapSports.



PowerLock®

Engineered to handle heavy loads, the patented PowerLocks become part of the understructure when engaged. Multi-patented Step-N-Snap design makes for no tools, no glues, and no toxic fumes.



Court Keeper

This vinyl based solution allows the concrete to breathe while providing better force reduction and ball performance than odorous recycled rubber.



SNAPSPORTS®

Three generations of continuous innovation™

SnapSports headquarters in Salt Lake City, Utah

From The Family That Created An Industry

The family of SnapSports created an industry over four decades ago. We are the originators of the outdoor backyard court industry you see today and the world's leading manufacturer and supplier of premium modular sport flooring for residential and commercial applications.

With SnapSports you can be assured you are getting the most advanced modular sports surfacing and sports components available on the planet. Our multi-patented and patent pending modular sports floors are top rated in the industry for performance and safe play.

Headquartered in Salt Lake City, Utah—SnapSports manufactures at their 150,000 square foot **ISO 9001:2015** certified facility, and is supported by an authorized global network. Unlike most other companies in the industry, SnapSports is completely in-house from design and engineering, to manufacturing all of our flooring products, to our expert authorized court building dealer network, who offer turnkey installations. We are proud to be a **100% American-made** modular sports flooring company.

Endorsements, Alliances, Standards, and Played On By:





“SnapSports Sports Flooring exemplifies the safety, performance, and quality that is important to the NBA.”

~ Adi Wilk – NBA, Director of Events



SnapSports, Inc.

2330 California Ave. , Salt Lake City, UT 84104

Toll Free: 1-800-664-3865 (DUNK) | **Phone:** 1-801-746-7555 | **Fax:** 1-801-746-7559

www.snapsports.com